

Place lockwasher (3) over end of tube (1) having the upset (2). Place end of tube, with upset, through large hole of bottom body (4) (bottom body has eight of the largest arms attached to it) and out the small bottom hole. Screw loop (5) on to end of tube. **Be sure loop is tight!**

Lower column (7) over tube (1) with wider/open end of column pointing toward bottom body (4). Before resting column on bottom body, push wire connectors (6) together until you hear them click. Rest column on bottom body; make sure bottom of column checks inside the large hole of the bottom body and the top of the tube goes through the center hole in the top of the column.

Thread wire connector (8) through **side hole, not center hole**, in cap (9) and middle body (10) (middle body has eight middle-sized arms attached to it). Stack the cap and body on top of column. Make sure that top of tube (1) goes through center holes of cap and middle body.

Place lockwasher (11) inside body (10) over top end of tube (1).

Screw tube (13), with hex-coupler (12) on to top end of tube (1). **USE PLIERS TO TIGHTEN THIS TUBE!**

Make wire connection (14) between wire connector (8) and either one of the two connectors coming from the middle body. Push connectors together until you hear them click.

Turn large arms (15) 90 degrees so that the light sockets point up.

Turn medium arms (16) 90 degrees so that the light sockets point up.

Go to other side... →

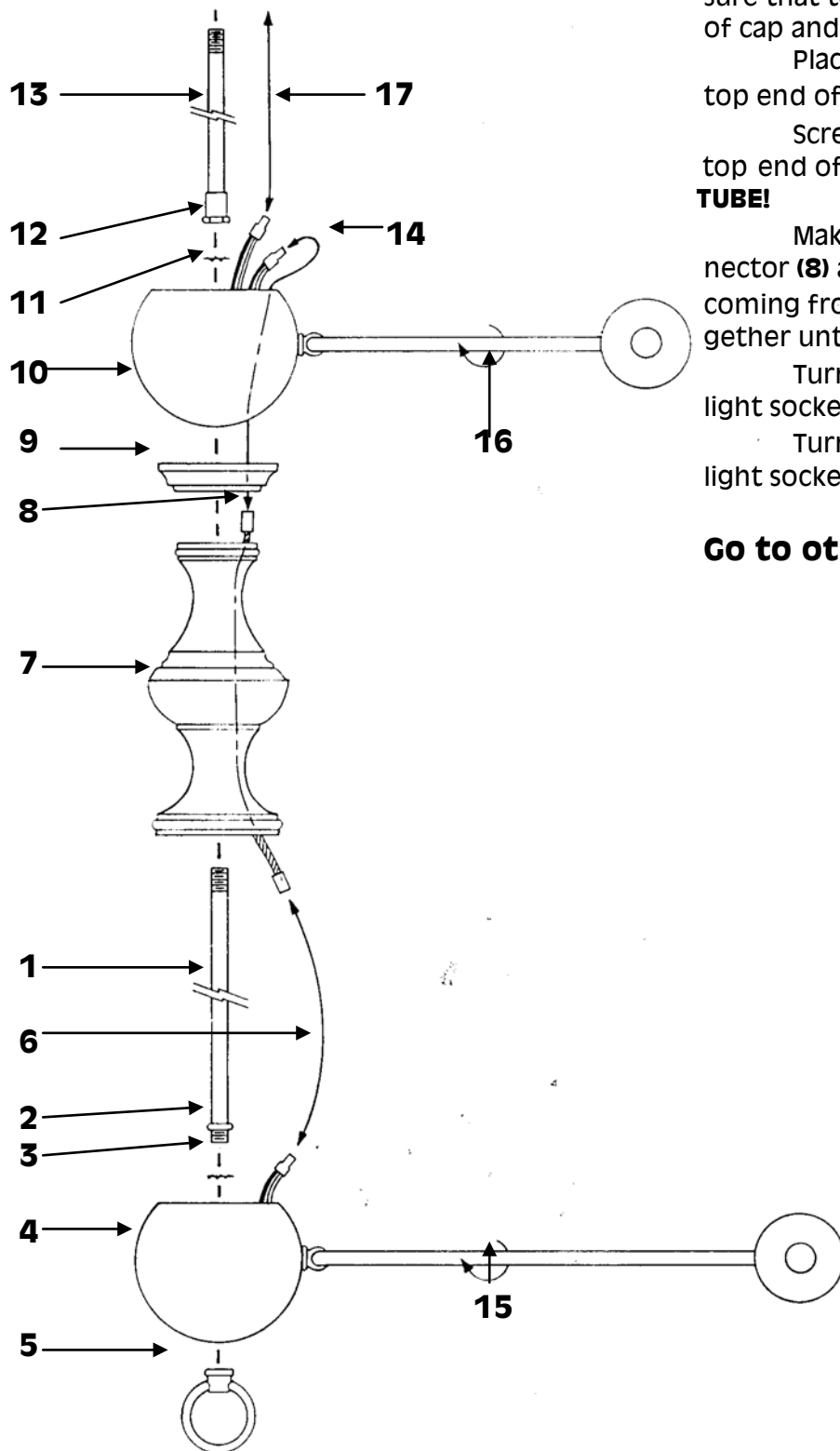

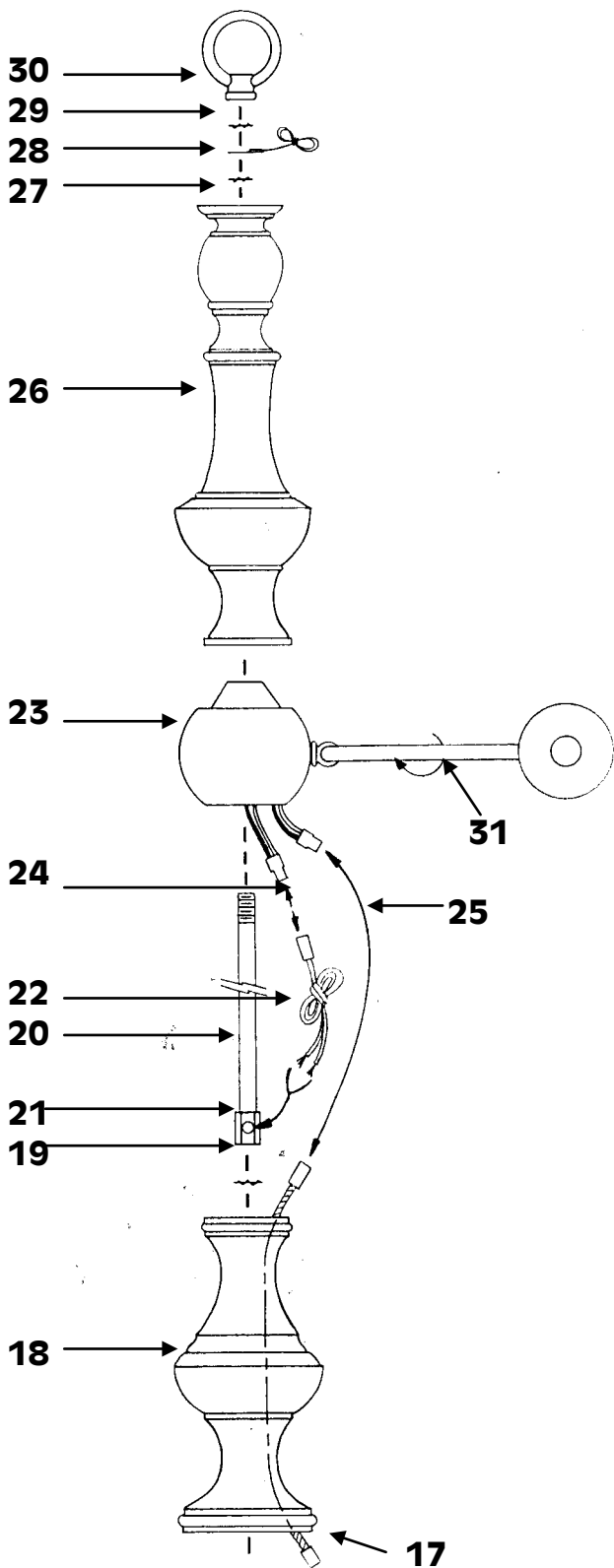

Lower column (18) over tube (13) with wider/open end of column pointing down toward middle body (10). Before resting column on body, push wire connectors (17) together until you hear them click. Rest column on middle body, making sure that the column bottom checks inside the large hole and the top of the tube (13) goes through the top-center column hole.

Place lockwasher (19) over top of tube (13).

Screw tube (20), with hex hickey (21), on to top end of tube (13). **USE PLIERS TO TIGHTEN TUBE!**

Find the coiled piece of power supply wire (22) provided with this fixture. One end has a wire connector and one end doesn't. Uncoil the wire and push the end without a wire connector through the hole in the hex-hickey (21) and **UP** through the tube (20). When the end of the cord comes up out of the top of the tube, pull that end until there are about three inches of cord left coming out of the hex-hickey hole.

Lower small body (23) over tube (20) so that the large hole is facing down toward the column. Before resting the body on the column, make two wire connections. First, make the connection (25) between the wire connector coming from the top of the column and either one of the wire connectors coming out of the small body. Push the connectors together until you hear them click. Second, make the connection (24) between the power supply wire and the second wire connector coming out of the small body. Push the connectors together until you hear them click. Now you can rest the small body on the column. Make sure that the top of the column fits inside the large hole of the small body.

Thread the power supply wire through the open end of column (26) (large hole) and out the small hole at the closed end. Lower the column over the tube (20) and the small body (23). Make sure that the open end of the column is facing the small body and the end of the tube (20) goes through the small hole at the top of the column.

Place one lockwasher (27) over the top of the tube (20).

Place the groundwire ring (28) over the lockwasher (27).

Place one lockwasher (29) over the top of the groundwire ring (28).

Screw loop (30) on to top of tube (20).

TIGHTEN LOOP!

Turn small arms (31) 90 degrees so that the light sockets point up.

Drawing 1 - Hanging Assembly

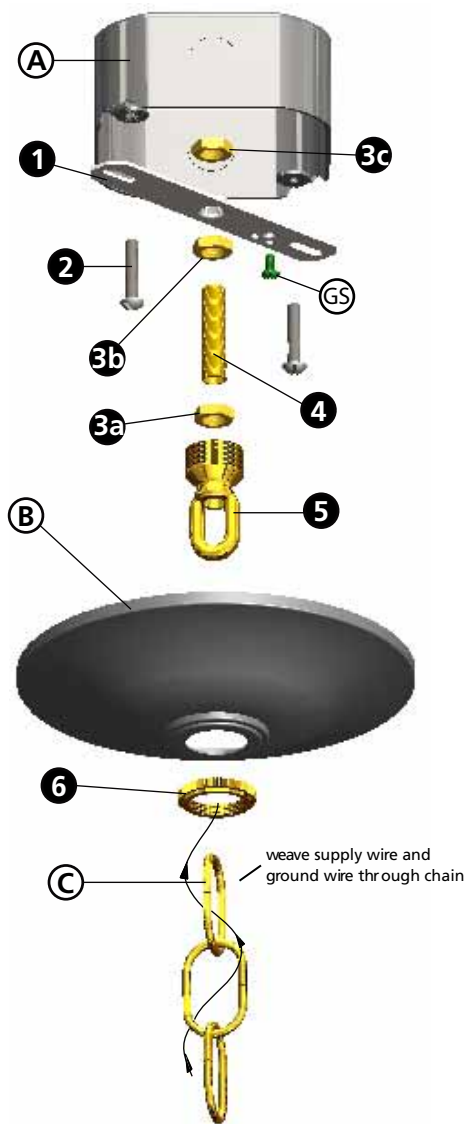

Drawing 2 Canopy Adjustment



▼ start here

SAFETY WARNING: READ WIRING AND GROUNDING INSTRUCTIONS (I.S. 18) AND ANY ADDITIONAL DIRECTIONS. TURN POWER SUPPLY OFF DURING INSTALLATION. IF NEW WIRING IS REQUIRED, CONSULT A QUALIFIED ELECTRICIAN OR LOCAL AUTHORITIES FOR CODE REQUIREMENTS.

1

1. Shut off electrical current before starting. If the fixture you are replacing is turned on and off by a wall switch, simply turn the switch off. If not, remove the appropriate fuse (or open the circuit breakers) until the fixture is dead.
 - DO NOT restore current - either by fuse, breaker or switch - until the new fixture is completely wired and in place.

2

1. fasten mounting strap (1) to outlet box (A) with the two 8-32 screws (2) -see Drawing 1.
2. Thread 2 - hex nuts (3a) and (3b) onto threaded tubing (4).
3. Thread one end of threaded tubing (4) into loop (5) a minimum of 1/2" to 3/4". Tighten hexnut (3a) against loop (5) to lock loop in position.
4. Thread other end of threaded tube (4) into mounting strap approximately 1/2".
5. Slip canopy (B) over loop (5) and adjust height of loop so half of the threaded area on the loop is exposed - see **Drawing 2** below. After loop height is adjusted, tighten hex nut (3b) up against mounting strap, tighten against mounting strap to lock loop and threaded tube in position.
6. Remove mounting strap (1) from junction box (A), and thread third hex nut (3c) onto end of threaded tube (4) above the mounting strap, tighten against mounting strap to lock assembly in position.
7. Remount mounting strap to junction box.

3

1. Taking the chain, determine the length you require to hang the fixture.
2. Attach one end of the chain to the top loop of the fixture - see **Drawing 2**.
3. Now slip loop collar (5) and canopy (B) onto chain.
4. Attach other end of chain to loop (4). Get assistance for this step since fixture may be heavy and difficult to hold while attaching the chain.

4

1. Unwrap supply wire and ground wire and weave them up through the chain.
2. Slip supply wire and ground wire through center of loop (4).
3. Connect ground wire to mounting strap (1) using green ground screw (6).
4. Make electrical connections from supply wire to fixture lead wires. Refer to instruction sheet (I.S. 18) and follow all instructions to make all necessary wiring connections.
5. Slip canopy up firmly against the ceiling and secure by turning the threaded collar (5) on loop (4) until tight.

Drawing 1 - Flush Mount

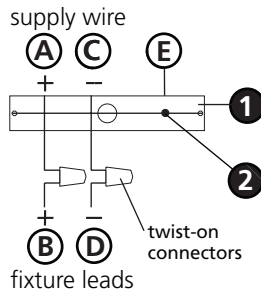

Drawing 2 - Chain Hung

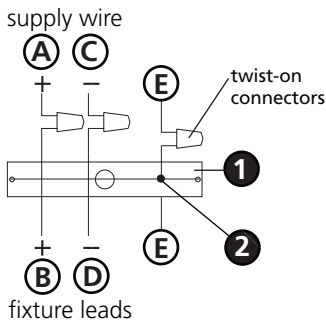

Drawing 3 - Post-Mount

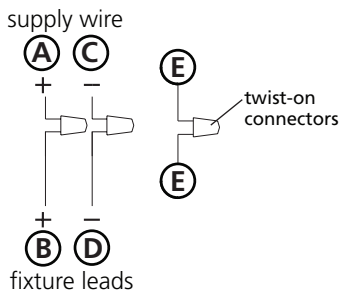

SAFETY WARNING: READ WIRING AND GROUNDING INSTRUCTIONS (I.S. 18) AND ANY ADDITIONAL DIRECTIONS. TURN POWER SUPPLY OFF DURING INSTALLATION. IF NEW WIRING IS REQUIRED, CONSULT A QUALIFIED ELECTRICIAN OR LOCAL AUTHORITIES FOR CODE REQUIREMENTS.

wiring instructions

Indoor Fixtures

1. Connect positive supply wire **(A)** (typically black or the smooth, unmarked side of the two-conductor cord) to positive fixture lead **(B)** with appropriately sized twist on connector - see **Drawings 1 or 2**.
2. Connect negative supply wire **(C)** (typically white or the ribbed, marked side of the two-conductor cord) to negative fixture lead **(D)**.
3. Please refer to the **grounding instructions** below to complete all electrical connections.

Outdoor Fixtures

1. Connect positive supply wire **(A)** (typically black or the smooth unmarked side of the two-conductor cord) to positive fixture lead **(B)** with appropriately sized twist on connector - see **Drawings 2 or 3**.
2. Connect negative supply wire **(C)** (typically white or the ribbed, marked side of the two-conductor cord) to negative fixture lead **(D)**.
3. Cover open end of connectors with silicone sealant to form a watertight seal.
 - If installing a wall mount fixture, use caulk to seal gaps between the fixture mounting plate (backplate) and the wall. This will help prevent water from entering the outlet box. If the wall surface is lap siding, use caulk and a fixture mounting platform specially.
4. Please refer to the **grounding instructions** below to complete all electrical connections.

grounding instructions

Flush Mount Fixtures

For positive grounding in a 3-wire electrical system, fasten the fixture ground wire **(E)** (typically copper or green plastic coated) to the fixture mounting strap **(1)** with the ground screw **(2)** - see **Drawing 1**.

Note: On straps for screw supported fixtures, first install the two mounting screws in strap. Any remaining tapped hole may be used for the ground screw.

Chain Hung Fixtures

Loop fixture ground wire **(E)** (typically copper or green plastic coated) under the head of the ground screw **(2)** on fixture mounting strap **(1)** and connect to the loose end of the fixture ground wire directly to the ground wire of the building system with appropriately sized twist-on connectors - see **Drawing 2**.

Post-Mount Fixtures

Connect fixture ground wire **(E)** (typically copper or green plastic coated) to power supply ground with appropriately sized twist-on connector inside post. Cover open end of connector with silicone sealant to form a watertight seal - see **Drawing 3**.